

Connecting Needs with Capabilities

# VeriFast™ IA

## User Manual

Ver. 1.5 – January 2025  
FDP-VFA-IA-UM-1.5-0125

## Product Sales and Support

---

The VeriFast™ IA is a component of a resistance welding system manufactured by:



For current contact information of various departments (Service, Sales, etc.), as well as CenterLine (Windsor) and Global Affiliate locations, please visit the [Contact Us](#) page on our website:

[www.cntrline.com](http://www.cntrline.com)

Head Office:

**CenterLine (Windsor) Limited**

415 Morton Drive

Windsor ON N9J 3T8

Canada

CAN. 519.734.8464

U.S. 313.962.1448

Toll Free: 800.820.6977

E-mail: [info@cntrline.com](mailto:info@cntrline.com)

## Disclaimer

This document is provided for informational purposes only. Due to the variety of uses for the product illustrated in this publication, those responsible for the application and use of this product must satisfy themselves that each application and use of the product meets all applicable laws, regulation codes, and standards. Users of this document should consult applicable federal, state, and local laws and regulations. CenterLine (Windsor) Limited does not, by the publication of this document, intend to urge action that is not in compliance with applicable laws, and this document may not be construed as doing so. CenterLine (Windsor) Limited has made every effort to ensure the accuracy and completeness of this document; however, because ongoing efforts are made to continually improve the capabilities of our products, we cannot guarantee the accuracy of the contents of this document. We disclaim liability for errors, omissions, or future changes herein.

In no event will CenterLine (Windsor) Limited be responsible or liable to any party for any personal injury, property or other damages of any nature whatsoever, whether special, direct, indirect, incidental, consequential or compensatory, directly or indirectly resulting from the publication, use of, or reliance on this document, and also from the use of the equipment described herein.

In issuing and making this document available, CenterLine (Windsor) Limited is not undertaking to render professional or other services for or on behalf of any person or entity. Nor is CenterLine (Windsor) Limited undertaking to perform any duty owed by any person or entity to someone else. Anyone using this document should rely on his or her own independent judgment or, as appropriate, seek the advice of a competent professional in determining the exercise of reasonable care in any given circumstances.

The illustrations, explanations, charts, and layout examples shown in this publication are intended solely for purposes of example. Since there are many variables and requirements associated with any particular installation, CenterLine (Windsor) Limited does not assume responsibility of liability (including intellectual property liability) for actual use based upon the information given in this publication.

Reproduction of the contents of this copyrighted publication, in whole or part, without written permission of CenterLine (Windsor) Limited, is prohibited.

# Table of Contents

---

|   |           |
|---|-----------|
| <b>Preface</b> .....  | <b>6</b>  |
| Who Should Use This Manual .....  | 6         |
| Purpose of This Manual.....   | 6         |
| Conventions Used in This Manual.....                                    | 6         |
| Terminology and Symbols Used Throughout This Manual.....                | 7         |
| <b>Safety Information</b> .....   | <b>8</b>  |
| Important Safety Information .....                                      | 8         |
| Handling the VeriFast™ IA .....   | 8         |
| Potential Hazards Related to VeriFast™ IA .....                         | 9         |
| Personal Protective Equipment .....                                     | 9         |
| <b>Equipment and Process Overview</b> .....                             | <b>10</b> |
| Intended Use of Equipment .....   | 10        |
| VeriFast™ IA Main Components .....                                      | 11        |
| VeriFast™ IA Configurations .....                                       | 12        |
| Base Mount Styles .....   | 12        |
| SYVR Extended Base Mount Style.....                                     | 13        |
| Tapered (SXCR) and Threaded (SXGR) Mount Styles .....                   | 13        |
| Clamp Mount Style.....  | 14        |
| Part Ordering Information .....   | 14        |
| <b>Required Services</b> .....  | <b>15</b> |
| Control Requirements.....   | 15        |
| Electrical Requirements.....  | 15        |
| Pneumatic Supply Requirements .....                                     | 15        |
| Water Supply Requirements.....  | 15        |
| Water Temperature .....   | 16        |
| Water Pressure .....  | 16        |
| Water Flow.....   | 16        |
| <b>Installation Guidelines</b> .....                                    | <b>17</b> |
| Important Safety Information .....                                      | 17        |
| Pre-Installation Tips and Requirements .....                            | 17        |
| Mounting the Base Mount Electrode .....                                 | 18        |
| Mounting the Tapered, Threaded, or Clamp Mount Electrode .....          | 19        |
| Connecting the VeriFast™ IA .....                                       | 20        |
| Connecting the VeriFast™ IA to the 4-pin Shielded Cable/Connector ..... | 21        |
| Determining Effective Resolution.....                                   | 21        |
| Establishing the Pneumatic Service Connection .....                     | 22        |

|   |           |
|---|-----------|
| Pneumatic Connection Diagram for VeriFast™ IA Weld Bodies with Retractable Pin, Using DSCO Valve (Not applicable to Clamp Mount Assemblies) .....     | 22        |
| Pneumatic Connection Diagram for VeriFast™ IA Weld Bodies with Retractable Pin, Using D3NC Valve (Not applicable to Clamp Mount Assemblies) .....     | 23        |
| Pneumatic Connection Diagram for VeriFast™ IA Weld Bodies Used in Ring Weld or Clinching Applications (Not applicable to Clamp Mount Assemblies)..... | 25        |
| Pneumatic Connection Diagram for VeriFast™ IA Weld Bodies with Non-Retractable Pin (Not applicable to Clamp Mount Assemblies) .....                   | 25        |
| Pneumatic Connection Diagram for VeriFast™ IA Clamp Mount Weld Bodies with Retractable Pin  | 26        |
| Pneumatic Connection Diagram for VeriFast™ IA Clamp Mount Weld Bodies with Non-Retractable Pin .....  | 26        |
| <b>Setup .....</b>  | <b>27</b> |
| Setting the Tolerance Windows for Fasteners.....  | 27        |
| <b>Maintenance .....</b>  | <b>28</b> |
| Important Safety Information .....  | 28        |
| Special Caution .....   | 28        |
| Servicing the VeriFast™ IA Base, Tapered, and Threaded Mount Electrode Assembly.....  | 28        |
| Servicing the VeriFast™ IA Clamp Mount Style Electrode Assembly .....   | 30        |
| Working Area Maintenance .....  | 33        |
| Cleaning the Equipment .....  | 33        |
| <b>Troubleshooting Quick Guide.....</b>   | <b>35</b> |
| Important Safety Information .....  | 35        |
| Troubleshooting Instructions .....  | 35        |
| <b>Decommissioning .....</b>  | <b>36</b> |
| Preparing for Storage .....   | 36        |
| <b>Index .....</b>  | <b>37</b> |

# Preface

---

## Who Should Use This Manual

Any person installing, using, or maintaining a VeriFast™ IA unit should use this manual.

## Purpose of This Manual

This manual describes the function, installation and necessary operating instructions for the proper use of the standard VeriFast™ IA. For assistance with any other customized products or non-standard applications, additional support is available from CenterLine. Please refer to the inside front cover of this manual for CenterLine contact information.

---



To prevent potentially serious or fatal injury, this manual must be read and understood in its entirety prior to installation, operation, or maintenance of any VeriFast™ IA.

---

### **IMPORTANT**

While every effort has been made to ensure that the product descriptions, procedures, and installation requirements included in this publication are accurate at the time of printing, CenterLine reserves the right to make product changes that might not be reflected in this document. Should you require additional information, please contact CenterLine, its agents, or distributors for assistance.

---

## Conventions Used in This Manual

This manual uses the following notations:

- Bulleted lists – such as this one – provide information, not procedural steps.
- Numbered lists provide sequential steps to follow or hierarchical information.
- When we refer you to a different section of this manual or to other documentation, the *section*, *chapter*, and *publication title* appear in *italics*.

## Terminology and Symbols Used Throughout This Manual

Throughout this manual, all the safety related notes have been identified by the following terms:



This symbol relates information about practices or situations that can lead to personal injury or death, property damage, or economic loss.

Attention statements help you to:

- Identify a hazard.
- Avoid a hazard.
- Recognize the consequences.

**IMPORTANT**

This symbol relates information that is critical for a successful application and understanding of the product.



This symbol indicates that serious hazards can occur due to pinch points.



This symbol indicates that you should read and understand the User Manual and all other applicable instructions before operating the equipment.



This symbol indicates that the equipment must be disconnected from all sources of power and put in the lockout state.



This symbol indicates that eye protection must be worn as a protection against dust, flying objects and particles.



This symbol indicates that appropriate safety shoes must be worn in order to avoid injuries from exposure to working environment.



This symbol indicates that the equipment must be kept dry, protected from excessive humidity and rain.

# Safety Information

---

## Important Safety Information

The VeriFast™ IA is used in conjunction with welding equipment and machinery. Therefore, as a supplement to the safety information offered in this manual for the VeriFast™ IA, all the safety considerations that pertain to the equipment used in conjunction with the VeriFast™ IA still apply and must be followed thoroughly.

Furthermore, all the existing plant safety regulations and other safety instructions from suppliers whose components are used with or around the VeriFast™ IA must be followed accordingly.

Any instructions contained in this manual that directly conflict with any other known safety procedures should be brought to CenterLine's immediate attention for clarification.

---



- Equipment is not to be modified, adapted, or changed without consulting the relevant sections of this manual or the manufacturer (please refer to the inside front cover of this manual for CenterLine contact information).
  - Before any installation, maintenance, or repair work is started, all sources of energy should be removed from the equipment using proper LOCKOUT procedures for electrical, pneumatic, and water services.
  - Pneumatic and cooling water lines represent potential hazards. Ensure all air and water lines are properly connected and secured prior to turning ON these services.
- 

## Handling the VeriFast™ IA

In order to prevent potentially serious personal injury, the VeriFast™ IA should be handled, installed, and operated according to the guidelines outlined in this document. Failure to follow the guidelines set forth here will bear unexpected and potentially dangerous results.

---

### **IMPORTANT**

Handle the VeriFast™ IA only by its weld body or base. Do not handle it by the tubing or compression fitting, as these are meant only to protect the IA wires inside. See images in Figure 1 below for reference.

If damage occurs to the tubing or wires, the weld body may not work correctly and the IA coil may require replacement.

---





Handling the VeriFast™ IA by its  
weld body or base is

**CORRECT**



Handling the VeriFast™ IA by the tubing or compression  
fitting is

**INCORRECT**

Figure 1 – Handling the VeriFast™ IA Assembly

## Potential Hazards Related to VeriFast™ IA

The VeriFast™ IA system has no specific hazards related to it. However, as the VeriFast™ IA is used in conjunction with other equipment such as welding equipment and machinery, robot, air supply, etc., the user should be aware of the warnings, hazards, and precautions related to the use of the equipment as a whole.



### Lockout Equipment

- Before starting to install the VeriFast™ components on the welding equipment, ensure that the equipment is disconnected from all sources of power and is in the lockout state.
- Before turning ON the equipment, make sure all components are assembled properly.
- Before removing the VeriFast™ from the welding equipment, make sure the equipment is turned OFF and is in the lockout state.

## Personal Protective Equipment

When handling, installing, and operating VeriFast™ equipment, the following items are recommended in addition to standard safety equipment:



Adequate eye protection, to prevent exposure of the eyes against flying objects, and particles.



Appropriate safety shoes, to protect feet against heavy loads, cuts, flying objects and electrical hazards.

# Equipment and Process Overview

---

## Intended Use of Equipment

The VeriFast™ IA (Integrated **A**mplifier) is a component of a resistance welding system. When properly installed in conjunction with resistance weld control equipment and used within the system's specification limits, the VeriFast™ IA is used to verify the presence and orientation of fasteners or materials. The VeriFast™ IA is not intended for any other use.

The VeriFast™ IA sensor signal is calibrated to measure and output the position of the fastener (nut or stud) weld pin in various stages of travel. The values of this signal are then compared to peripherally programmed set point values (with tolerances). Results that do not match the set point values can trigger either an interruption in the cycle, or a warning message indicating that the process has fallen outside the set value. These occurrences can indicate a potential part quality issue.

The set point values may indicate:

- Weld Pin Extended Position (System ready to load part and fastener)
- Weld Proceed (Presence and Correct Fastener Orientation)
- Weld Complete (Nut Welded)
- Nut is Upside Down
- No Fastener Detected
- No Part Detected
- Weld Pin Retracted Position (Allowing safe part removal by robot or other process operations)

The VeriFast™ IA system has the ability to detect differences as small as **0.02 mm (0.0009")**. However, actual performance is dependent on the effective resolution of the control system to which it is integrated. For more information refer to section *Determining Effective Resolution* on page 21.

The following example shows a nut application. It demonstrates the difference between correct fastener orientation, and other error conditions.

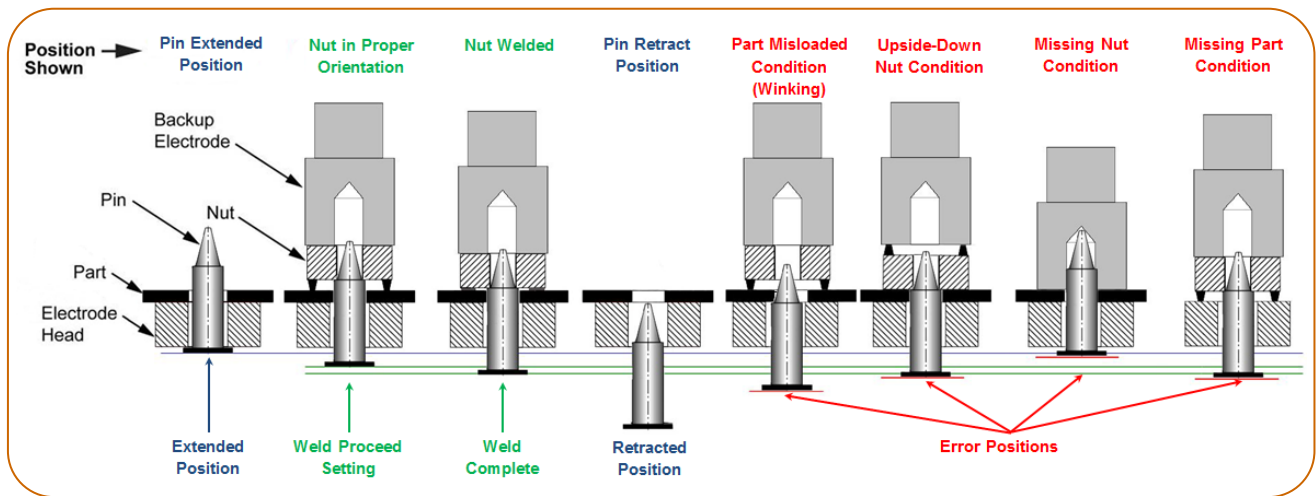

Figure 2 – Nut Detection and Orientation

## VeriFast™ IA Main Components

The VeriFast™ IA has a robust construction that allows for fast and easy component changes. A standard VeriFast™ IA configuration is illustrated Figure 3 below. **IMPORTANT:** Do not try to use an LVDT Weld Pin Assembly with a VeriFast™ IA, as they are not compatible.

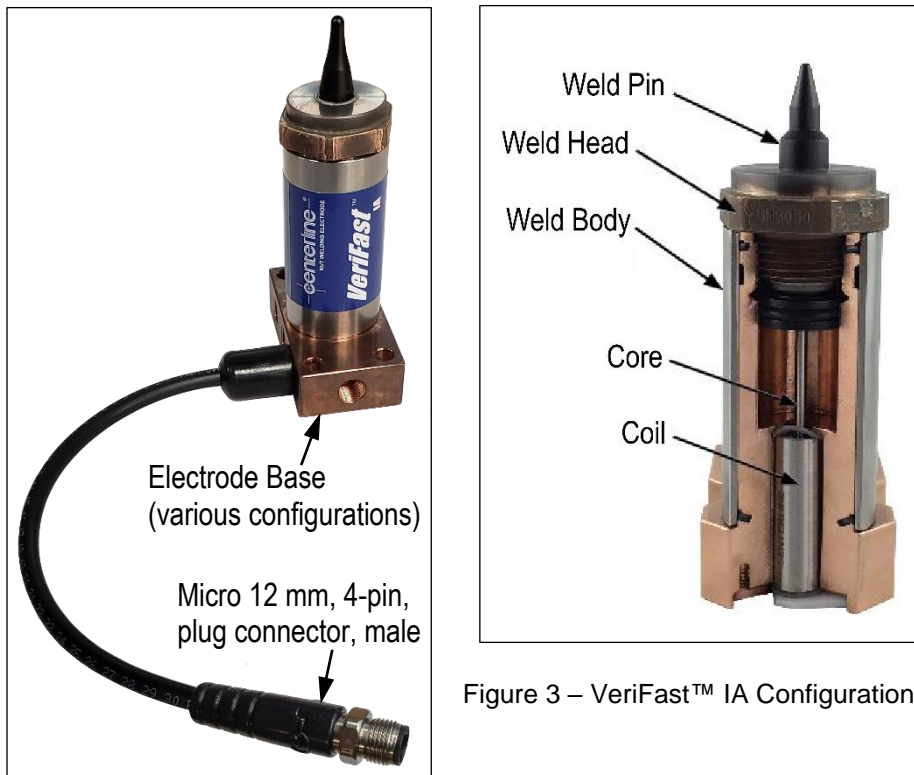
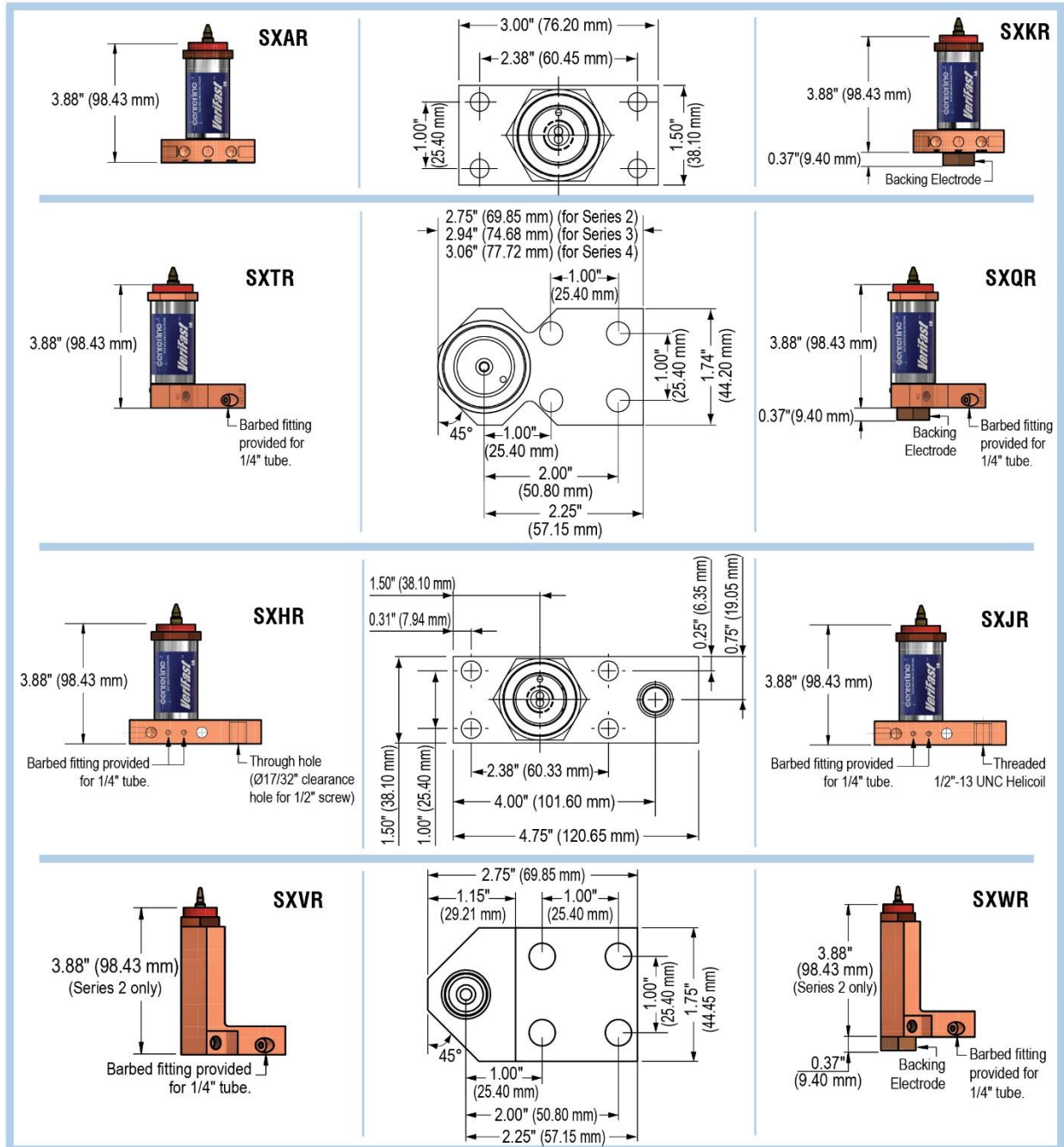

Figure 3 – VeriFast™ IA Configuration

# VeriFast™ IA Configurations

## Base Mount Styles

**Note:** The VeriFast™ IA (shown below) and corresponding VeriFast™ LVDT (illustrated in a separate user manual) weld bodies have equivalent dimensions and mounting holes.



- All Weld Bodies above work with a Weld Pin Assembly with a 31 mm core. See images on the right.
- Series 2, 3, and 4 are available for most Base Mount configurations, with Series 3 being preferred for all applications, unless clearance or welding issues exist. Exceptions are SXVR and SXWR weld bodies, which are Series 2 only.
- The Series number must be consistent between all components (Body, Pin, and Head).
- All Weld Bodies above have a 22 mm pin stroke.

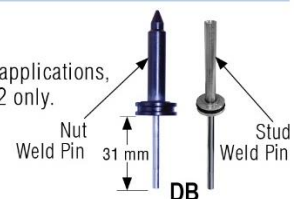

## SYVR Extended Base Mount Style

**Note:** The VeriFast™ IA (shown below) and corresponding VeriFast™ LVDT (illustrated in a separate user manual) weld bodies have equivalent dimensions and mounting holes.

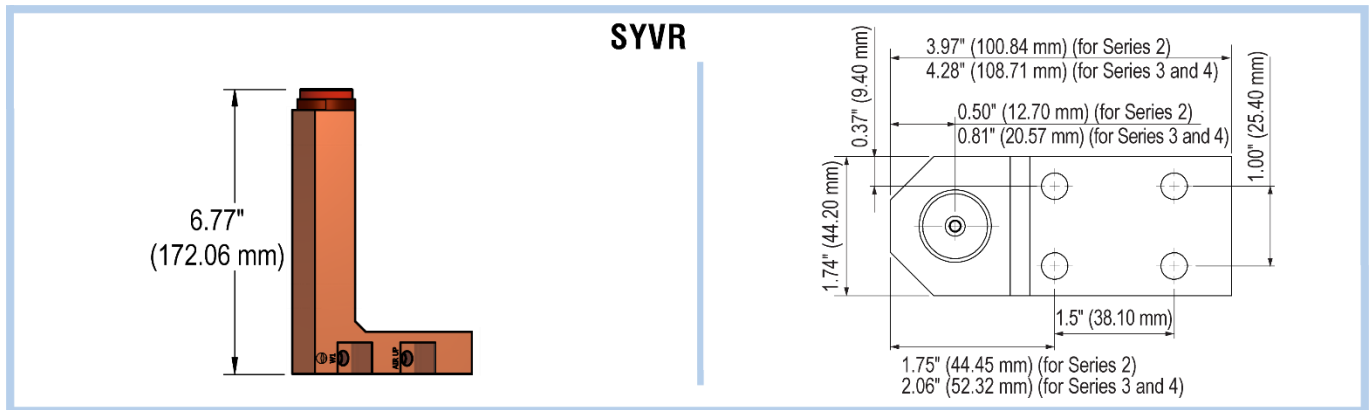

- The SYVR Extended Base Mount weld body works with a Stud Weld Pin Assembly with a 74 mm core:
- Series 2, 3, and 4 are available for the SYVR configuration.
- Series 3 is preferred for all applications, unless clearance or welding issues exist.
- The Series number must be consistent between all components (Body, Pin and Head).
- The SYVR weld body is recommended for stud weld applications (not nut applications).
- The SYVR weld body has a 50 mm weld pin stroke only (not 22 mm).

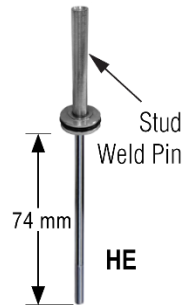

## Tapered (SXCR) and Threaded (SXGR) Mount Styles

**Note:** The VeriFast™ IA (shown below) and corresponding VeriFast™ LVDT (illustrated in a separate user manual) weld bodies have equivalent dimensions and mounting holes.

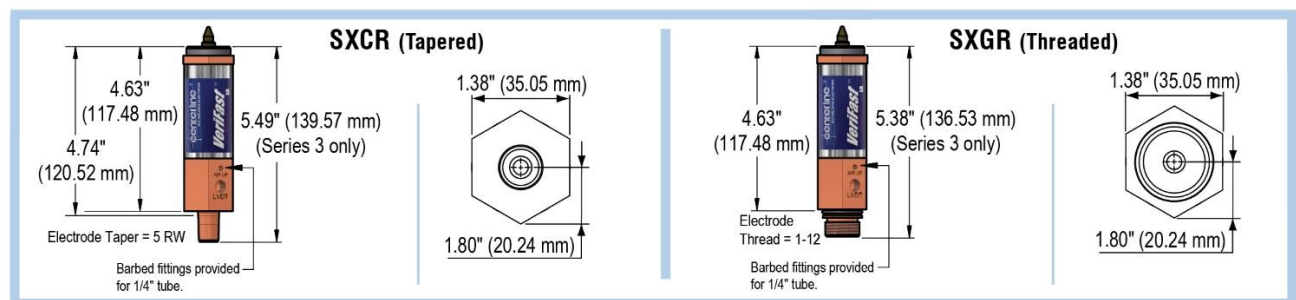

- The Weld Bodies above work with a Weld Pin Assembly with a 31 mm core. See images on the right.
- These Weld Bodies are available in Series 3 only.
- The Series number must be consistent between all components (Body, Pin, and Head).
- The SXCR and SXGR Weld Bodies have a 22 mm pin stroke.

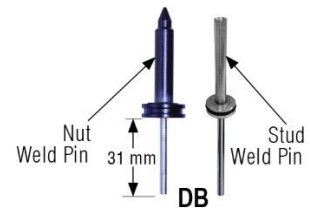

## Clamp Mount Style

**Note:** The VeriFast™ IA (shown below) and corresponding VeriFast™ LVDT (illustrated in a separate user manual) weld bodies have equivalent dimensions and mounting holes.

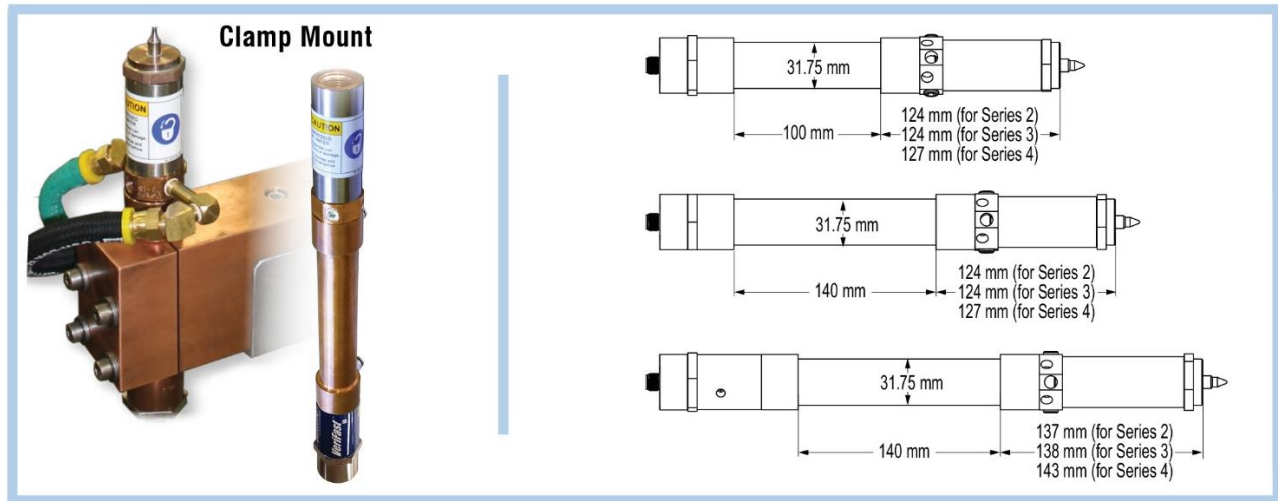

- The Clamp Mount weld body works with the nut and stud weld pins shown on the right:
- Series 2, 3, and 4 are available for the Clamp Mount configuration.
- Series 3 is preferred for all applications, unless clearance or welding issues exist.
- The Series number must be consistent between all components (Body, Pin, and Head).
- Adapter Length:
  - 100 (mm) - Works with 22 mm pin stroke only (not 50 mm).
  - 140 (mm) - Works with both 22 mm and 50 mm pin strokes.

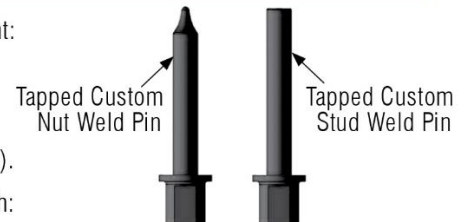

- Pin Stroke Length:
  - 22 (mm) - Works with both 100 mm and 140 mm adapters.
  - 50 (mm) - Works with 140 mm adapter only (not 100 mm).

## Part Ordering Information

Each VeriFast™ IA weld body is marked with labels providing information about your specific configuration. When ordering a replacement component, please check your own equipment and have that specific part number readily available.

### IMPORTANT

For optimal equipment performance and full warranty support, CenterLine consumables must be used.



# Required Services

---

## **IMPORTANT**

When establishing the services (electrical, pneumatic, water) to your VeriFast™ IA, all service requirements illustrated in the current section must be satisfied.

---

## Control Requirements

Minimum recommended control connection requirements are as follows:

An analog input is required to receive the VeriFast™ IA system signal and a 15 bit resolution is recommended to achieve ideal operating performance. ***IMPORTANT:*** The length of the analog signal cable should be limited to 50 ft. (15 m). See Figure 4 for component reference. Actual performance is dependent on the effective resolution of the control system to which the VeriFast™ IA system is integrated. For more information refer to *Determining Effective Resolution* on page 21.

## Electrical Requirements

The VeriFast™ IA power supply requirements are as follows:

- **Volts:** 24 V DC
- **Amps:** 40 mA.

## Pneumatic Supply Requirements

The operating performance of the VeriFast™ IA is closely tied to the quality and configuration of the air supply system.

- Tubing: M6 (3/8") weld spatter resistant
- Ideal operating pressure: 3.5 bar (50 psi)
- Air shall be filtered and non-lubricated. The air must be clean, dry, and free of contaminants. A pneumatic filter with 5 micron element size is recommended for air cleanliness.
- For installation guidelines, please refer to the *Establishing the Pneumatic Service Connection* section starting on page 21.

## Water Supply Requirements

The welding equipment requires water cooling to dissipate the heat generated in the resistance welding process. The operating performance of the equipment is closely tied to the quality and configuration of the water supply system.



- Improper water hookup will result in insufficient cooling, which may cause severe equipment damage or personal injury. Always ensure proper safety precautions.
  - After the cooling circuit is connected, ensure that there are no kinks in any of the lines, and all fittings have been tightened and checked for leaks.
- 

The requirements for the cooling water are as follows:

### **Water Temperature**

- Water temperatures between 24°C to 30°C (75°F to 85°F) are recommended.
- The water temperature should not exceed 30°C (85°F) after the load, since high water temperatures will prevent the equipment from being adequately cooled.
- In the event that the water temperature exceeds 30°C (85°F), the equipment should be operated at a reduced duty cycle to prevent damage to the equipment.
- In humid operating environments, ensure that the water temperature is above the dew point to prevent condensation on the equipment.

### **Water Pressure**

- The differential water pressure across the welding equipment (i.e., the difference of the water pressure between the water IN and water OUT) must be 35 PSI or greater to ensure proper water flow.

### **Water Flow**

- The VeriFast IA electrode assembly requires a flow of 1 GPM (4 LPM) to maintain proper operation temperature.



# Installation Guidelines

---

## Important Safety Information

Please review the *Safety Information* section starting on page 8 and *Personal Protective Equipment* section starting on page 9.

---



Before installation procedure for the VeriFast™ IA is started, ensure that all power, air, and water services are de-energized and locked out.

---

CenterLine recommends that qualified personnel (e.g., electrical or mechanical technician) be involved with the setup and operation of the VeriFast™ IA:

- For mechanical, pneumatic, fluid, and electrical services.
- A qualified weld engineer or quality control personnel – for tolerances and calibration when required.

## Pre-Installation Tips and Requirements

Before starting to install the VeriFast™ IA, please be aware of the following:

- If replacing older 'legacy' (pre-LVDT) bodies, the mounting hole pattern of the VeriFast™ IA will be different than the existing hole pattern. An adapter plate may be required to mount the IA body, as the new mounting holes would be drilled too close to the existing ones.
- Base Mount IA weld bodies are approximately 1/2" taller than 'legacy' bodies. Threaded and Tapered mounted IA bodies are approximately 1 3/4" taller than 'legacy' bodies.
- If replacing older 'legacy' or Smart Electrode bodies, ensure that the air, water, and electrical connections of the new IA weld bodies will work with the existing equipment. Please consider part, tooling and robot clearance.
- CenterLine strongly recommends using Air Blow-By, where air is constantly exhausted past the weld pin to prevent weld spatter from accumulating. Please refer to the *Establishing the Pneumatic Service Connection* section starting on page 22.
- Ensure that the controls solution is adequate, as illustrated by the bullets below. (For reference, consult the *Connecting the VeriFast™ IA* section starting on page 20 of this manual. Also, refer to the VeriFast™ *MicroView User Manual* section: "*Wiring the Ports of VeriFast™ MicroView*").
  - If wiring to an analog card, confirm that the analog card has enough analog channels.
  - If using VeriFast™ MicroView, ensure that enough digital I/O ports are available.
  - Confirm that you have the appropriate number and type of cables and connectors.

## Mounting the Base Mount Electrode

### IMPORTANT

The weld electrode's mounting on industrial equipment (e.g., platen, sub-plate, etc.) is usually a copper-to-copper contact surface that will transfer current; therefore, both surfaces need to be clean and free from oil, dirt, and any other contaminants.

Any contamination will increase the resistance of the joint, which in turn causes less current to flow and, therefore, an increase in temperature will result. A thin coating of oil from your fingers is enough to cause a change in the resistance. For this reason, it is very important to clean and install the copper components correctly.

Once the surfaces are cleaned, apply Kopr-Shield®, and then install the copper components immediately, to prevent surface oxidation which will cause a poor connection. As long as the connection remains tight, there should be no concern for heat buildup or loss of current at the connection. If, however, during routine service it is discovered that the joint is loose, then it should be completely disassembled, cleaned and reassembled.

To mount the Electrode Body on machinery or fixture, follow the steps below:

1. Use Scotch-Brite™ to clean the electrode's mounting contact surface. Ensure all pitting and oxidation on the bottom of the weld body is removed. Wipe the surface with a clean cloth.

Pitting and oxidation on the bottom of weld body



2. Use Scotch-Brite™ to clean the surface of the platen on which the IA weld body will be installed. Wipe the surface with a clean cloth.



3. Coat the bottom of the weld body with Kopr-Shield®.



4. Mount the weld body on the sub-plate using the four (4) socket head screws and Nord-Lock washers provided with the equipment. Tighten the screws to 8 N·m (6 ft-lb or 72 in-lb).

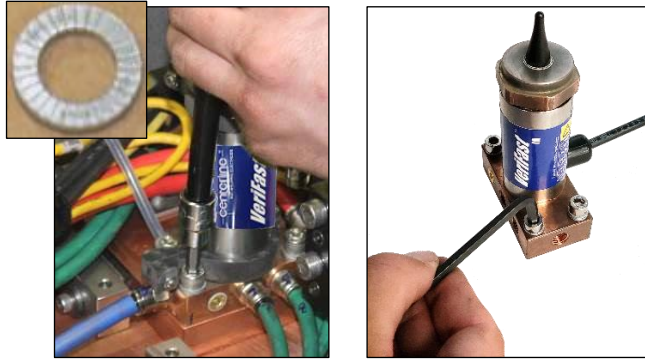

Regardless of weld body type, ensure that the bend radius of the IA cable is at all times at least 0.79" (20 mm) (see illustrations below as examples). A smaller bend will cause kinks and damages to the IA cable.

**IMPORTANT**



## Mounting the Tapered, Threaded, or Clamp Mount Electrode

The mounting procedure for the Tapered, Threaded, or Clamp Mount Electrode is self-explanatory, according to the type of the weld body and the equipment on which the weld body is installed.

**IMPORTANT**

When the weld electrode is mounted on industrial equipment (e.g., arm of a weld gun, etc.), the contact surface can be **copper-to-copper** or **copper-to-aluminum**. Regardless of the contact area type, all contact surfaces must be clean and free from oil, dirt, and any other contaminants.

The recommended cleaning procedure is to wipe all the contact areas clean, buff them with Scotch-Brite™, and wipe them clean with a soft cloth. For **copper-to-aluminum** contact components only, be sure to apply Penetrox™ A-13 Electrical Joint to the contact surfaces.

The components should then be installed immediately.

As long as the connection remains tight, there should be no concern for heat buildup or loss of current at the connection. If, however, during routine service it is discovered that the joint is loose, then it should be completely disassembled, cleaned and reassembled as shown above.

**IMPORTANT**

Regardless of weld body type, ensure that the bend radius of the IA cable is at all times at least 0.79" (20 mm) (see image). A smaller bend will cause kinks and damages to the IA cable.



## Connecting the VeriFast™ IA

Use a **micro 12 mm, 4-pin, shielded cable (max. 50 ft. (15 m))** to establish the connection between the VeriFast™ IA Electrode and the PLC.

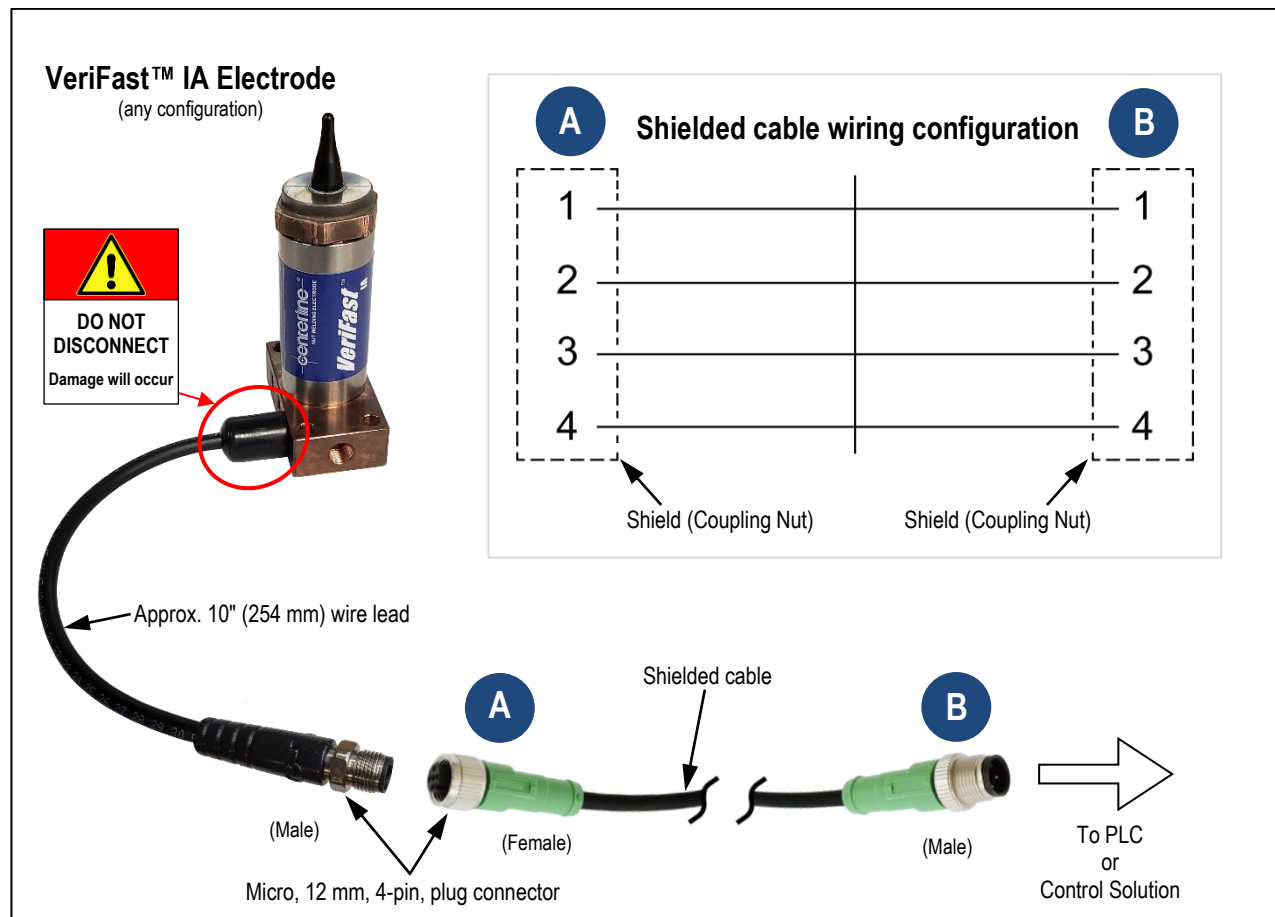



Figure 4 – Connecting the VeriFast™ IA

## Connecting the VeriFast™ IA to the 4-pin Shielded Cable/Connector

VeriFast™ IA bodies have a 4-pin connector with a shielded hex coupling nut (see Table 1).

Table 1 – Connecting the VeriFast™ IA to the 4-pin Shielded Cable/Connector

| VeriFast™ IA to 4-pin Shielded Cable   |            |                        |
|--|------------|------------------------|
| Image  | Connection | Description            |
|  <p>Shielded Hex Coupling Nut</p> | Pin 1      | +24 V DC               |
|  | Pin 2      | 0 – 10 V Analog Signal |
|  | Pin 3      | 0 V DC                 |
|  | Nut        | Shield                 |

**Note:** Previous VeriFast™ IA bodies have a 4-pin connector with a knurled coupling nut which requires grounding Pin 4 on the panel end of the circuit (see Table 2).

Table 2 – Connecting Previous VeriFast™ IA to 4-pin Shielded Cable/Connector

| VeriFast™ IA to 4-pin Shielded Cable   |            |                        |
|--|------------|------------------------|
| Image  | Connection | Description            |
|  <p>Knurled coupling nut</p> | Pin 1      | +24 V DC               |
|  | Pin 2      | 0 – 10 V Analog Signal |
|  | Pin 3      | 0 V DC                 |
|  | Pin 4      | Shield                 |

## Determining Effective Resolution

In a measurement system, resolution is defined as the smallest increment of position change which can be detected and indicated by the output.

### Factors Affecting Analog Resolution

In sensors providing an analog output, practical resolution is determined primarily by:

- The noise on the output and/or signal lines
- The input resolution of the device to which the sensor is connected.

**Noise** is the main limiting factor in most systems. Even if the resolution of the sensor is theoretically infinite, it's only possible to resolve signal changes that are larger than the amount of noise on the output signal lines. Output changes smaller than the noise level are “lost” in the noise.

### Determining Resolution – A Practical Example:

Sensor: VeriFast™ IA

Stroke Length: 22 mm (0.866”)

Output Range: 0-10 V DC

Noise Level: 10 mV

In this example, the infinitely variable output signal of the IA sensor is limited by the fact that there is 10 mV of noise present on the signal lines. Since 10 mV is 1/1000th of the entire 0-10 V range, the smallest position change that can be detected is 1/1000th of the working stroke range of 22 mm (0.866")

$$22 \text{ mm} / 1000 = 0.022 \text{ mm} \quad (0.866" / 1000 = 0.000866")$$

So a good, practical estimate of the resolution is 0.022 mm (0.00087").

Assuming a lower noise level would result in a better estimated resolution (e.g., 5 mV = 0.011 mm (0.0004")).

**Input Resolution** – Analog inputs on industrial controls must “digitize” an analog signal in order to utilize the information. This is accomplished using an Analog-to-Digital Converter (ADC). An ADC accepts the analog signal and assigns a discrete, digital value to a defined signal value.

For example, a 15-bit ADC can represent a 0-10 V signal as any one of 32,768 “numbers” ( $2^{15} = 32,768$ ). Using the above example:

$$22 \text{ mm} / 32,768 = 0.0006713 \text{ mm} \quad (0.866" / 32,768 = 0.0000264")$$

***Important!*** – Note that, in the above example, the limitation as a result of noise is still the determining factor. Even though the input resolution can be as good as 0.0006713 mm (0.0000264"), the 10 mV noise level would still limit practical resolution to 0.022 mm (0.00087").

## Establishing the Pneumatic Service Connection

The primary function of the compressed air supplied to the VeriFast™ IA is to control the actuation of the weld pin. Based on the Pin type (i.e., Retractable or Non-Retractable), type of application (e.g., nut/stud welding, welding ring projections, clinching applications) and the mount type of the Weld Body (e.g., base, clamp mount, etc.), use one of the pneumatic configurations below. Note that in applications for IA Weld Bodies with Retractable Pin, either a DSCO or a D3NC valve can be used, as shown in the first two subsections below (with illustrations in Figure 5 and Figure 6).

### Pneumatic Connection Diagram for VeriFast™ IA Weld Bodies with Retractable Pin, Using DSCO Valve (Not applicable to Clamp Mount Assemblies)

CenterLine recommends using a double solenoid center open (DSCO) valve to extend and retract the weld pin (see Figure 5 below). In this 3-position center open valve, the center open position reduces air consumption when the valve is de-energized. Also, using a 3-port shuttle valve ensures continuous air blow off in all pin positions.

**(Note:** A D3NC valve can also be used instead of the DSCO valve. See the next sub-section).

While referring to the diagram in Figure 5, please consider the following:

- In home/load position, the solenoid extending the pin should be energized to facilitate loading and locating the stamping and/or location of fastener.
- After a weld complete signal is received, the solenoid extending the pin must be de-energized, and the solenoid to retract the pin must be energized to facilitate the removal of the finished part.



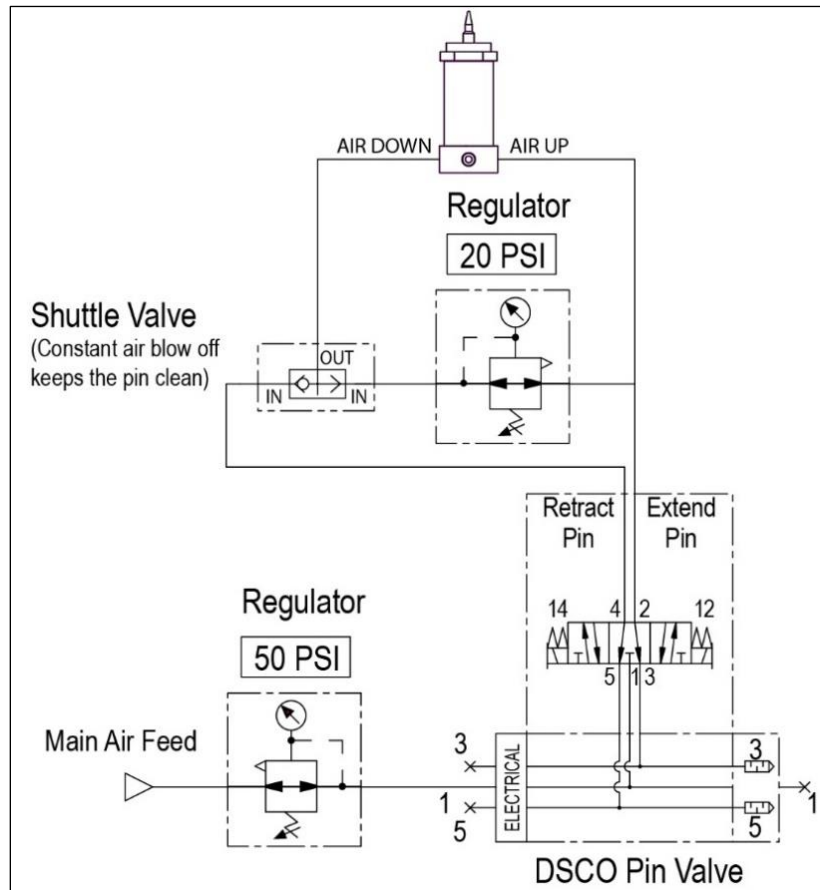

Figure 5 – Pneumatic Connection Diagram for VeriFast™ IA Weld Body with Retractable Pin, using DSCO Valve (Not applicable to Clamp Mount Assembly)

### Pneumatic Connection Diagram for VeriFast™ IA Weld Bodies with Retractable Pin, Using D3NC Valve (Not applicable to Clamp Mount Assemblies)

CenterLine recommends that a dual 3-way normally closed (D3NC) double solenoid valve can also be used to extend and retract the weld pin, as shown in the pneumatic diagram in Figure 6 below. Note that in this configuration, the D3NC valve would replace the DSCO valve and other pneumatic components shown in Figure 5 above in the previous sub-section.

The benefits of using the D3NC valve are:

- It allows for independent control of the pin extend and retract/air blow off positions.
- Shuttle valve is no longer required.
- The air blow-off is turned ON when the OHMA® cylinder intensifies, so smaller fasteners are not being blown off the weld pin.
- It helps provide accurate IA readings, as it eliminates the blown off air getting trapped due to the seal created in ring weld applications.
- Eliminates the leaking air noise nuisance.

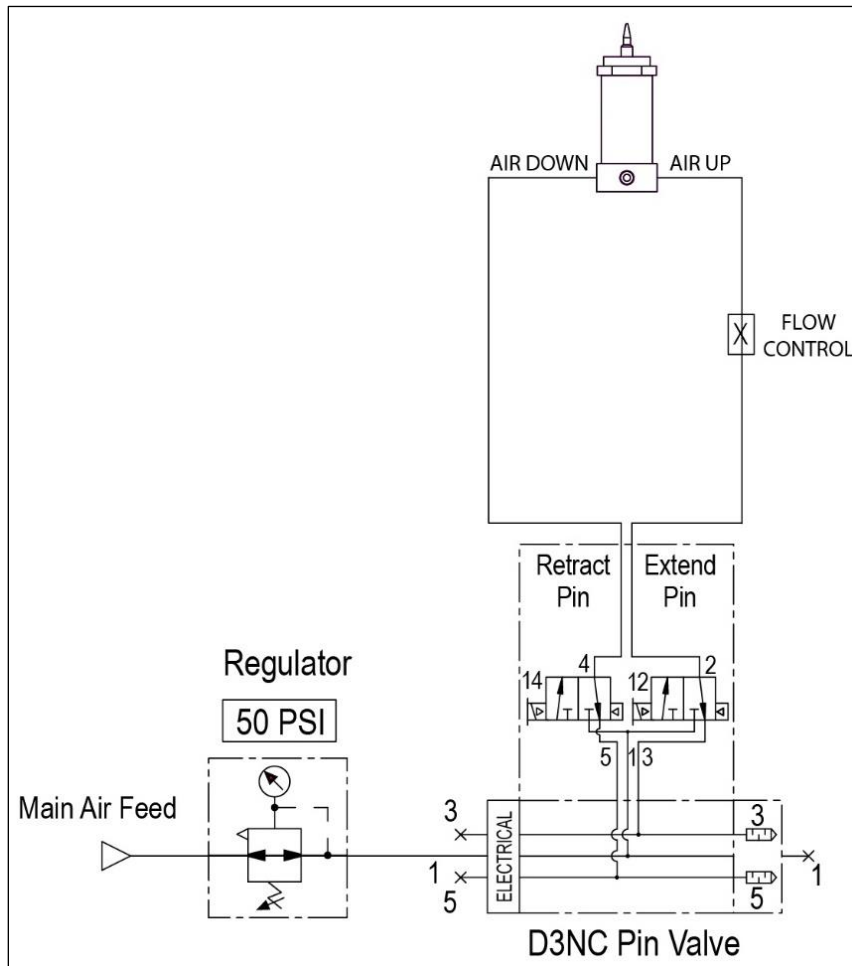

Figure 6 – Pneumatic Connection Diagram for VeriFast™ IA Weld Body with Retractable Pin, using D3NC Valve (Not applicable to Clamp Mount Assembly)



**Pneumatic Connection Diagram for VeriFast™ IA Weld Bodies Used in Ring Weld or Clinching Applications (Not applicable to Clamp Mount Assemblies)**

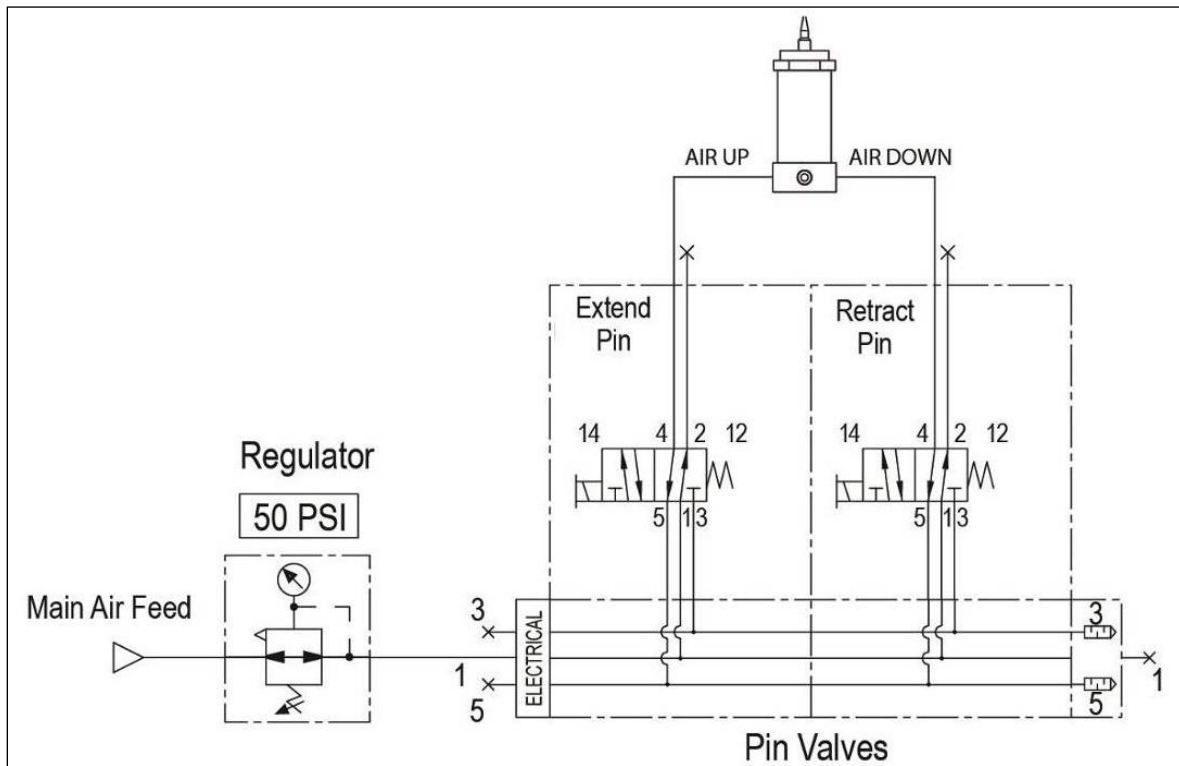

Figure 7 – Pneumatic Connection Diagram for VeriFast™ IA Weld Body Used in Welding Ring Projections or Clinching Applications (Not applicable to Clamp Mount Assembly)

**Pneumatic Connection Diagram for VeriFast™ IA Weld Bodies with Non-Retractable Pin (Not applicable to Clamp Mount Assemblies)**

For proper operation, the AIR UP Regulator **must** be set at a higher pressure than the AIR DOWN Regulator.

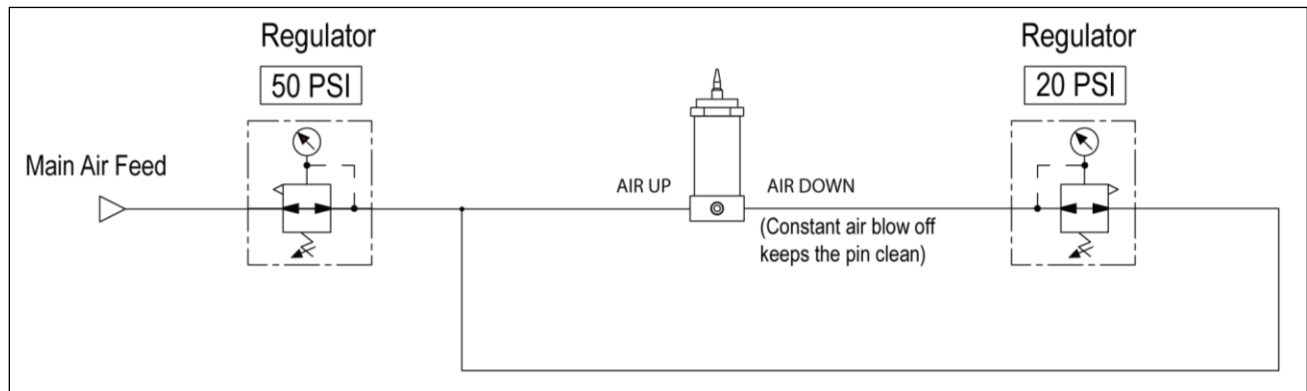

Figure 8 – Pneumatic Connection Diagram for VeriFast™ IA Weld Body with Non-Retractable Pin (Not applicable to Clamp Mount Assembly)

## Pneumatic Connection Diagram for VeriFast™ IA Clamp Mount Weld Bodies with Retractable Pin

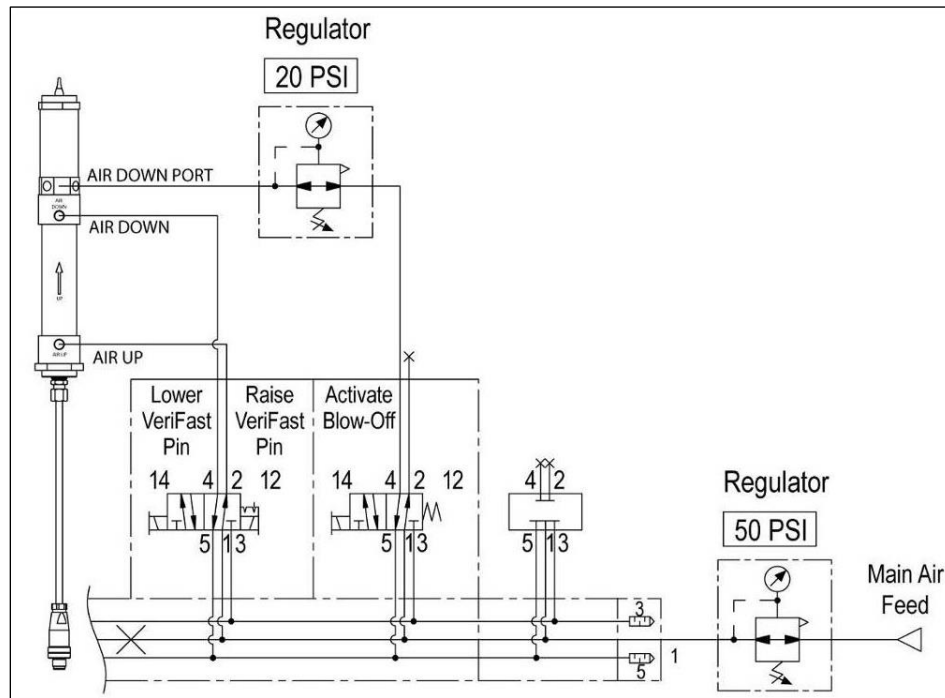

Figure 9 – Pneumatic Connection Diagram for VeriFast™ IA Clamp Mount Weld Body (Only) with Retractable Pin

## Pneumatic Connection Diagram for VeriFast™ IA Clamp Mount Weld Bodies with Non-Retractable Pin

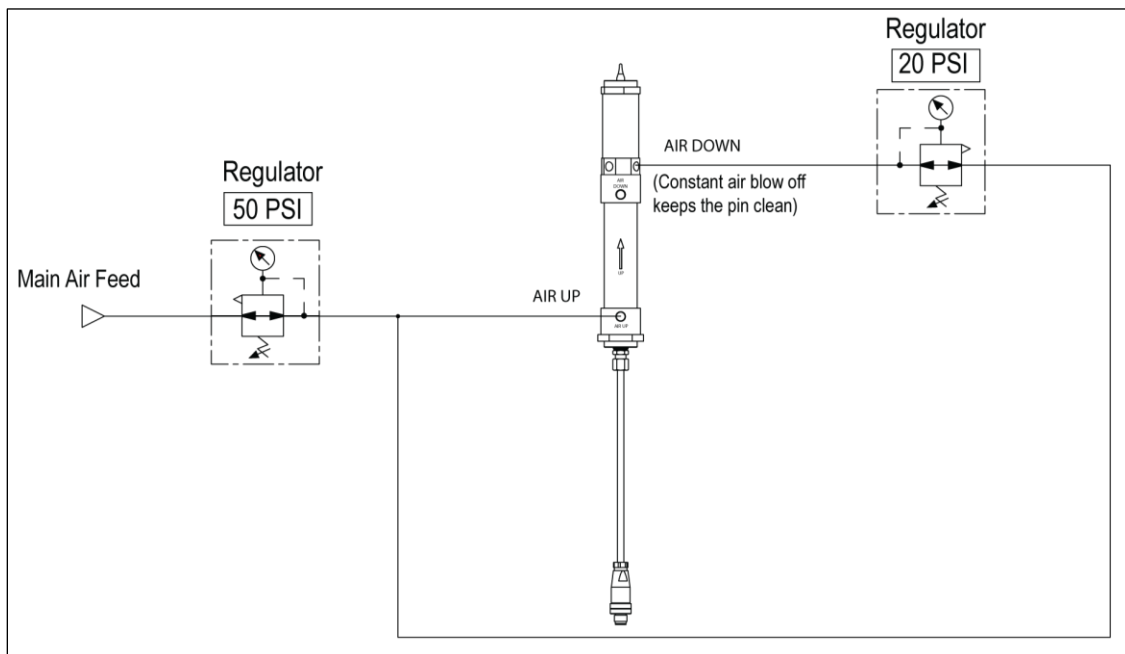

Figure 10 – Pneumatic Connection Diagram for VeriFast™ IA Clamp Mount Weld Body (Only) with Non-Retractable Pin

# Setup

## Setting the Tolerance Windows for Fasteners

Use the following instructions to set the tolerance window for the VeriFast™ IA and LPT solutions:

1. Gather a sample of at least ten (10) fasteners that you are using. (Using a greater number of fasteners will produce a more accurate result)
2. Ensure that the selected fasteners are all within dimensional tolerance.
3. With the Weld Pin fully extended, load the stamping and fastener in correct orientation.
4. Advance the weld actuator to make contact with the fastener and record the Weld Pin (IA) position.
5. Retract the weld actuator, ensuring that the Weld Pin returns to fully extended position.

**Note:** Steps 6, 7, and 8 below only apply when welding Nuts. Skip to Step 9 if welding Studs.

6. (*Nuts only*) Remove the fastener, and re-load it in upside down orientation.
7. (*Nuts only*) Advance the weld actuator and record the Weld Pin (IA) position.
8. (*Nuts only*) Retract the weld actuator, ensuring that the Weld Pin returns to fully extended position.
9. Repeat Steps 1 through 5 (include Steps 6, 7 and 8 if nut welding) for the entire sample of fasteners.
10. Average all correctly placed fastener readings. If nuts are being used, average the upside down readings as well.
11. Select a tolerance that will reliably allow correctly placed fasteners to proceed, while always rejecting upside down fasteners. See the Example to the right for illustration.

**Note:** If there are similar fasteners in the vicinity that could also be mistakenly loaded onto this electrode, these should also be checked to verify that they cannot be welded.

It is important to keep in mind that the tolerance window must be small enough to reject all upside down fasteners, while large enough to accept stamping and fastener variances. If the Correct and Upside Down windows overlap, a different Weld Pin design may be necessary. Please contact CenterLine for more details.

### Example

| Fastener# | Correct | Upside Down |
|-----------|---------|-------------|
| 1         | 13,356  | 15,223      |
| 2         | 13,478  | 15,336      |
| 3         | 13,322  | 15,347      |
| 4         | 13,415  | 15,358      |
| 5         | 13,345  | 15,213      |
| 6         | 13,449  | 15,374      |
| 7         | 13,411  | 15,346      |
| 8         | 13,301  | 15,339      |
| 9         | 13,463  | 15,260      |
| 10        | 13,383  | 15,289      |
| Average   | 13,392  | 15,309      |
| Max       | 13,301  | 15,209      |
| Min       | 13,478  | 15,374      |

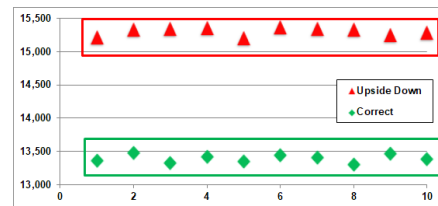

In this case, set the tolerance at 13,400 with a range of  $\pm 300$  counts. The 'pass' window would be between 13,100 and 13,700. This allows every correctly loaded fastener to be welded, while rejecting every incorrectly loaded fastener.

# Maintenance

---

## Important Safety Information

---

### IMPORTANT

Situations not covered in this section should be referred directly to CenterLine for further assistance (Please refer to the inside front cover of this book for CenterLine contact information).

---

Please review the *Safety Information* section starting on page 8 and *Personal Protective Equipment* section starting on page 9.

### Special Caution

Regardless of configuration, **do not attempt to remove/loosen the sleeve or fitting on the VeriFast™ IA Electrode.** Damage to the equipment will occur!



## Servicing the VeriFast™ IA Base, Tapered, and Threaded Mount Electrode Assembly

**Important:** For the Clamp Mount style, please see the sections that follow.

Although the VeriFast™ IA unit is a sealed, low maintenance device, the Weld Pin and the Electrode Head need to be replaced at regular intervals. In addition, by following the procedure illustrated below, other internal components can be inspected and/or replaced as needed.

### Step 1

Remove the air and water services from the system. Then, unthread and remove the Electrode Head from the Weld Body.

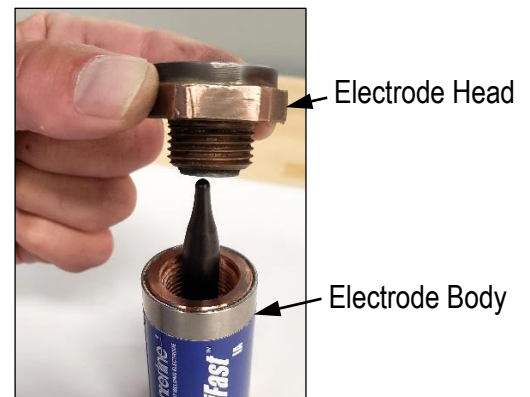

### Step 2

Remove the used Weld Pin Assembly from the Electrode Body and discard.

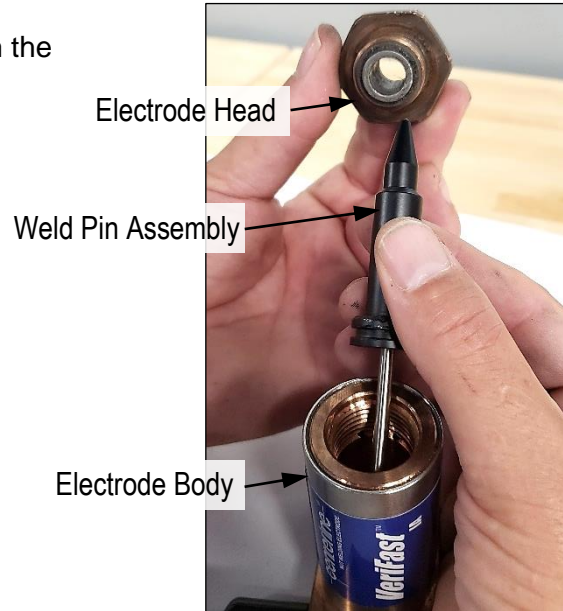

### Step 3

Apply a small amount of grease to the O-ring on the new Weld Pin Assembly (**Note:** Magnalube-G grease is recommended).

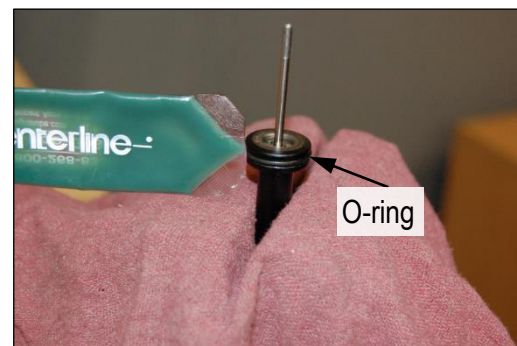

### Step 4

Manually insert the new Weld Pin Assembly fully into the Electrode Body, aligning the core with the Coil, while being careful not to damage the O-Ring on the Weld Pin.



### Step 5

Thread on the Electrode Head and tighten to the corresponding torque (according to the weld body series):

- 15 ft/lbs. – for Series 2 weld bodies
- 30 ft/lbs. – for Series 3 weld bodies
- 100 ft/lbs. – for Series 4 weld bodies.



## Servicing the VeriFast™ IA Clamp Mount Style Electrode Assembly

Although the VeriFast™ IA Clamp Mount Assembly is a sealed, low maintenance device, the Weld Pin and the Electrode Head need to be replaced at regular intervals. In addition, by following the procedure illustrated below, other internal components can be inspected and/or replaced as needed.

### Step 1

Remove the water service from the system.  
Retract the weld pin to remove force internally on the weld head.



### Step 2

Unthread and remove the Electrode Head from the Weld Body.

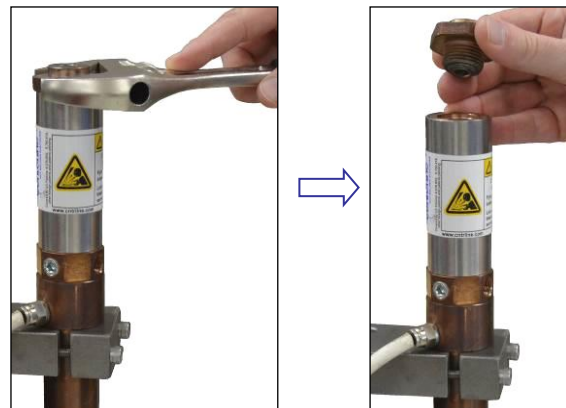

### Step 3

Extend the weld pin to “service position” exposing the flats of the piston rod above the weld body. Then, remove the air from the system.

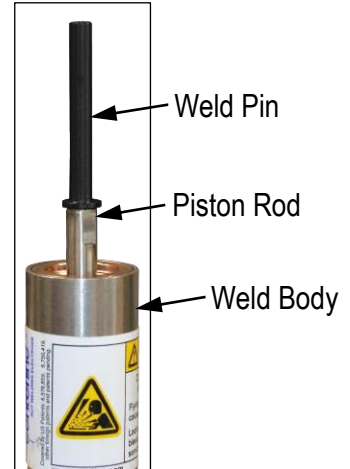

### Step 4

Remove the weld pin from the piston rod.

If only the Pin and Head need to be replaced, the procedure ends here. To install a new Pin and Head, skip directly to Step 9 on page 33, then finish by reversing the steps performed to this point (Step 4 to Step 1).

If other internal components need to be inspected/replaced, continue with Step 5 below.

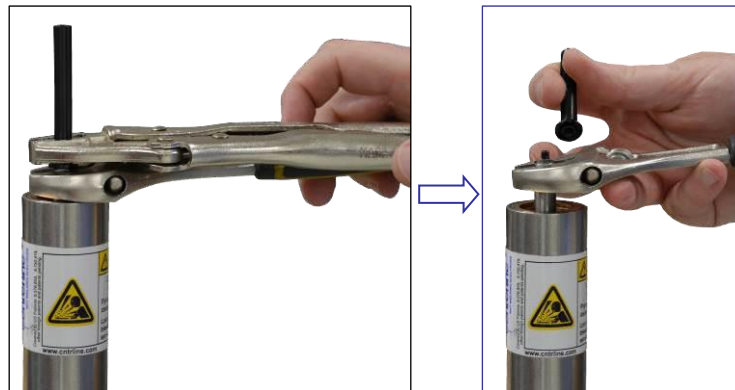

### Step 5

Remove the IA insert from the base of the assembly.

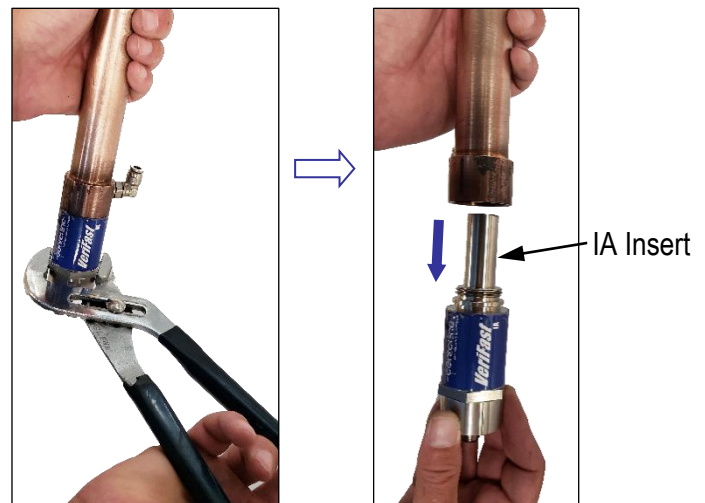



**Step 6**

Manually push the piston rod from above and it will pass through the bottom of the adapter.

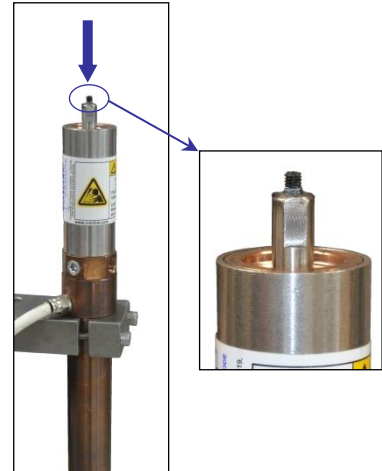

**Step 7**

Remove the piston rod assembly.



**Step 8**

Replace and lubricate O-rings if required.

**Note:** Magnalube-G grease is recommended for lubrication of O-rings and piston rod shaft.





### Step 9

Inspect all components for wear and replace as needed. Assemble all components in reverse order, manually lowering the pin to ensure that the core properly aligns/inserts into the IA coil.

**Note 1:** Loctite 243 (Blue) is recommended when re-attaching the weld pin to the piston rod assembly. Allow sufficient curing time for the Loctite before resuming production.

**Note 2:** At the end of the re-assembly procedure, thread on the Electrode Head and tighten to the corresponding torque (according to the weld body series):

- 15 ft/lbs. – for Series 2 weld bodies
- 30 ft/lbs. – for Series 3 weld bodies
- 100 ft/lbs. – for Series 4 weld bodies.



## Working Area Maintenance

Good housekeeping is an important element of any preventative maintenance program. Some cleaning should be done at regular intervals, usually when the electrodes are being changed. More extensive cleaning may occur during regular preventative maintenance of the equipment.

## Cleaning the Equipment

### IMPORTANT

The VeriFast™ IA assembly should be kept clean at all times.



### Lockout Equipment

- Before starting to clean the VeriFast™ IA, ensure that the equipment is disconnected from all sources of power and is in the lockout state.
- Before turning ON the equipment, make sure all components are assembled properly.



### Keep Dry

- Do not power wash the VeriFast™ IA.
- Do not immerse the VeriFast™ IA into water.

For optimal operation of the equipment, the VeriFast™ IA must be frequently inspected for contamination and buildup, and should be kept as clean as possible. The operating performance of the IA in the sensing process is highly dependent on the cleanliness and good

maintenance of the equipment. Excessive contamination and buildup reduce the performance accuracy and service life of the VeriFast™.

A routine examination of the VeriFast™ IA should be performed on a regular basis to verify that all connections are tight and in good order.

The exterior of the VeriFast™ IA should be cleaned using the following guidelines:

- Clean the VeriFast™ as you would normally do with industrial equipment. Wipe the outside of the VeriFast™ with a dry, clean cloth.
- Use only dry ice or chemicals that are compatible with the materials used in the VeriFast™ and surrounding equipment (e.g., copper, brass, aluminum, carbon steel, stainless steel, and rubber (used as a protection for the IA)).
- Do not power wash. As mentioned above, dry ice can be used for proper cleaning.

# Troubleshooting Quick Guide

## Important Safety Information

Please review the *Safety Information* section starting on page 8 and *Personal Protective Equipment* section starting on page 9.

### IMPORTANT

Follow all plant safety procedures and guidelines, as well as all safety instructions given in this manual before performing any troubleshooting procedures. Only certified personnel should perform any troubleshooting tasks on the machinery.

## Troubleshooting Instructions



### Lockout Equipment

- Before starting to troubleshoot the VeriFast™ IA, ensure that the equipment is disconnected from all sources of power and is in the lockout state.
- Before turning ON the equipment, make sure all components are assembled properly.

To troubleshoot the VeriFast™ IA unit, please refer to Table 3 that follows.

Table 3 – Troubleshooting the VeriFast™ IA

| Problem:  | Possible Cause:   | What To Do:   |
|---|---|---|
| Power ON, but no signal or value from VeriFast™ unit                                  | Is the VeriFast™ IA unit connected / wired properly?              | Confirm that the connection of the cable is fastened completely and firmly.                                 |
|   |   | Check the cable between the VeriFast™ IA unit and network connection for damage or compromise of integrity. |
|   |   | Check control power supply.   |
|   |   | Refer to Table 1 on page 21 to ensure correct wiring.   |
| Measurement Value will not respond to Pin movement                                    | Is the VeriFast™ IA unit connected / wired / calibrated properly? | Refer to Table 1 on page 21 to ensure correct wiring of the field connector.                                |
|   | Is an LVDT or another incorrect weld pin installed?               | Install the correct weld pin.   |
| Measurement Value responds but with reduced resolution and reverse of expected travel | Is the VeriFast™ IA unit connected / wired / calibrated properly? | To confirm wiring, refer to Table 1 on page 21.   |

# Decommissioning

---

## Preparing for Storage

The following guidelines should be followed when removing a VeriFast™ IA from service:

- Disconnect the VeriFast™ IA system from the external supplies (electrical, air) and identify the connections to facilitate a future installation.
- The storage location must be clean, dry, and not expose the VeriFast™ IA system to mechanical or thermal damage. If the VeriFast™ will be covered, there should be some air circulation to prevent condensation.

# Index

---

## 4

4-pin Shielded Cable/Connector, 20

## B

Base Mount IA Electrode  
Mounting, 18  
Servicing the Assembly, 28

## C

Clamp Mount IA Electrode  
Mounting, 19  
Servicing the Assembly, 30

Cleaning Equipment, 33

Components  
VeriFast IA, 11

Compressed Air. See Pneumatic

Configuration  
VeriFast IA, 12

Connecting  
the 4-pin Shielded Cable, 20  
the VeriFast™ IA, 20  
the VeriFast™ IA to 4-pin Shielded Cable,  
21

Connection  
Establish Pneumatic Service, 22  
Pneumatic for Clinching Applications, 25  
Pneumatic for IA Clamp Mount Weld Bodies  
with Non-Retractable Pin, 26  
Pneumatic for IA Clamp Mount Weld Bodies  
with Retractable Pin, 26  
Pneumatic for IA Weld Bodies with Non-  
Retractable Pin, 25  
Pneumatic for IA Weld Bodies with  
Retractable Pin using D3NC Valve, 23  
Pneumatic for IA Weld Bodies with  
Retractable Pin using DSCO Valve, 22

Pneumatic for Weld Ring Projections  
Applications, 25

Control Requirements, 15

## D

D3NC Valve, 23  
Decommissioning, 36  
DSCO Valve, 22

## E

Effective Resolution  
Determining the, 21  
Factors Affecting Analog Resolution, 21  
Input Resolution, 22  
Noise, 21

Electrical Supply Requirements, 15

Electrode  
Pneumatic Connection for Clinching  
Applications, 25  
Pneumatic Connection for IA Clamp Mount  
Weld Bodies with Non-Retractable Pin, 26  
Pneumatic Connection for IA Clamp Mount  
Weld Bodies with Retractable Pin, 26  
Pneumatic Connection for IA Weld Bodies  
with Non-Retractable Pin, 25  
Pneumatic Connection for IA Weld Bodies  
With Retractable Pin using D3NC Valve, 23  
Pneumatic Connection for IA Weld Bodies  
With Retractable Pin using DSCO Valve, 22  
Pneumatic Connection for Weld Ring  
Projections Applications, 25  
Servicing the IA Base Mount Electrode, 28  
Servicing the IA Clamp Mount Electrode, 30  
Servicing the IA Electrode Assembly, 28  
Servicing the IA Extended Base Mount  
Electrode, 28  
Servicing the IA Tapered Mount Electrode,  
28  
Servicing the IA Threaded Mount Electrode,  
28

VeriFast IA Configuration, 12  
VeriFast IA Main Components, 11

## Equipment

Intended Use, 10  
Overview, 10  
Servicing the IA Electrode Assembly, 28, 30

## Extended Base Mount IA Electrode

Servicing the Assembly, 28

## F

### Fastener

Correct Orientation, 9, 11  
Detection and Orientation, 9, 11  
Error Detected Conditions, 9, 11  
Setting the Tolerance Windows, 27

## H

### Hazards

Potential Hazards, 9

## I

IA Electrode. *See* Electrode

### Installation, 17

Connecting the VeriFast™ IA, 20  
Mounting the Base Mount Electrode, 18  
Mounting the Tapered/Threaded/Clamp Mount IA Electrode, 19  
Pneumatic Service Connection, 22  
Pre-Installation Requirements, 17  
Pre-Installation Tips, 17

### Instructions

Safety, 8

## M

### Maintenance, 28

Cleaning Equipment, 33  
Servicing the IA Electrode Assembly, 28, 30  
Working Area, 33

### Mounting

the IA Base Mount Electrode, 18

the IA Tapered/Threaded/Clamp Mount Electrode, 19

## N

No Fastener Detected Condition, 10

No Part Detected Condition, 10

### Nut

Detection and Orientation, 9, 11  
Upside Down Condition, 10

## P

Part Ordering for VeriFast IA, 14

### Pneumatic

Connection for Clinching Applications, 25  
Connection for IA Clamp Mount Weld Bodies with Non-Retractable Pin, 26  
Connection for IA Clamp Mount Weld Bodies with Retractable Pin, 26  
Connection for IA Weld Bodies with Non-Retractable Pin, 25  
Connection for IA Weld Bodies with Retractable Pin using D3NC Valve, 23  
Connection for IA Weld Bodies with Retractable Pin using DSCO Valve, 22  
Connection for Weld Ring Projections Applications, 25  
Pneumatic Supply Requirements, 15  
Service Connection, 22

### Pre-Installation

Requirements, 17  
Tips, 17

Process Overview, 10

## R

Required Services, 15

Control Requirements, 15  
Electrical Requirements, 15  
Pneumatic Supply Requirements, 15  
Water Supply Requirements, 15

### Requirements

Control, 15  
Electrical Supply, 15

- Pneumatic Supply, 15
- Pre-Installation, 17
- Water Supply, 15

Resolution. See Effective Resolution

## S

### Safety

- Information, 8
- Personal Protective Equipment, 9
- Potential Hazards, 9

### Services

- Control Requirements, 15
- Electrical Requirements, 15
- Pneumatic Supply, 15
- Water Supply, 15

### Servicing

- the Base Mount IA Electrode, 28
- the Clamp Mount IA Electrode, 30
- the Extended Base Mount IA Electrode, 28
- the IA Electrode Assembly, 28, 30
- the Tapered Mount IA Electrode, 28
- the Threaded Mount IA Electrode, 28

### Set Point Values

- No Fastener Detected, 10
- No Part Detected, 10
- Nut is Upside Down, 10
- Weld Complete, 10
- Weld Pin Extended Position, 10
- Weld Pin Retracted Position, 10
- Weld Proceed, 10

Setting the Tolerance Windows for Fasteners, 27

Setup, 27

### Specifications

- Control Requirements, 15
- Electrical Requirements, 15
- Pneumatic Requirements, 15
- Water Flow Requirements, 16
- Water Pressure Requirements, 16
- Water Requirements, 15
- Water Temperature Requirements, 16

### Storage

Preparing for Storage, 36

## T

### Tapered Mount IA Electrode

- Mounting, 19
- Servicing the, 28

### Threaded Mount IA Electrode

- Mounting, 19
- Servicing the, 28

### Tolerance

- Setting the Tolerance Windows, 27

### Torque

- Electrode Head, 30
- Weld Head, 33

### Troubleshooting, 35

## V

### Valve

- D3NC, 23
- DSCO, 22

### VeriFast IA

- Components, 11
- Configuration, 12
- Effective Resolution, 10
- Part Ordering, 14

### VeriFast™ IA

- Connecting, 20

## W

### Water

- Flow, 16
- Pressure, 16
- Supply Requirements, 15
- Temperature, 16

### Weld

- Complete, 10
- Pin Extended Position, 10
- Pin Retracted Position, 10
- Proceed, 10

### Working Area Maintenance, 33